

# MABER MBC 500/120-M

## Features & benefits

The MABER MBC 500 hoist is our exclusive solution for sites without three-phase power.

The MBC500 can accommodate most building materials including 8' x 4' sheets of plasterboard or plywood that can be stood upright in the cage.

Has a robust SWL of 500kg and the capacity to transport three people.

What sets it apart is its versatility, allowing simultaneous transportation of both goods and personnel.

- Single Phase operation with a 500kg SWL.
- Platform Size 1600 X 1320mm.
- Can be set up to 120m.
- 3 Passengers / 500kg Goods hoist.
- Lifting speed 12 m/m.
- Different ramp configurations available to suit sites.



Platform at base



Platform at the landing position



## Power requirements



Dedicated 240v 32a  
Commando Socket.



32a Single Phase C Type MCB.

Can be paired with our 20kva Generator



	<b>Maber MBC500</b>
<b>Maximum Height</b>	120m
<b>Lifting Capacity - Goods Mode</b>	500kg
<b>Lifting Capacity - Personnel Mode</b>	3 persons
<b>Lifting Speed - Goods Mode</b>	12 m/min
<b>Lifting Speed - Personnel Mode</b>	12 m/min
<b>Power Source</b>	240v Electric
<b>Breaker Rating</b>	32a Single Phase C Type MCB
<b>Power Requirements (Within 2m of the hoist base)</b>	Dedicated 240v 32a Commando Socket
<b>Start up Current (Max)</b>	16a
<b>Running Current (Max)</b>	12a
<b>Cage Dimensions (Internal)</b>	W 1320mm - L 1600mm
<b>Approx. Ground Space Required</b>	2920mm x 3050mm
<b>Approx. Minimum Access Required</b>	Contact us
<b>Approx. Gate Opening Dimentions</b>	2000mm +

**Technical information**

Standard configuration.

Platform size.

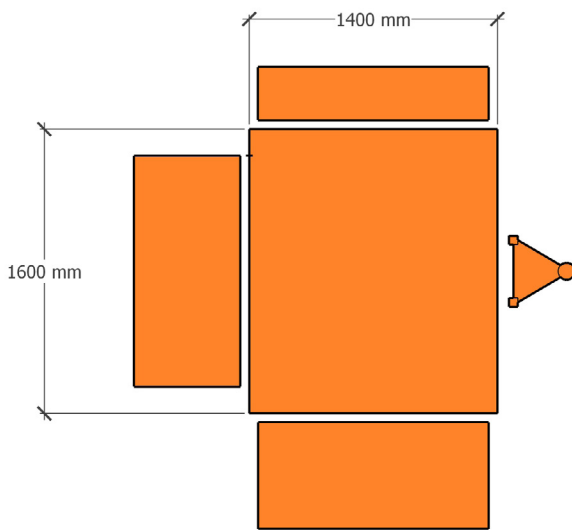

Reversed configuration.

Platform size.

