

GEDA 300Z/ZP

Features & benefits

The GEDA 300Z/ZP transport platform offers a multitude of advantages. Its compact design, measuring only 0.85m when folded, ensures transportation to almost any construction site, even passing through a narrow passageway.

This hoist is ideal for tight spaces and up onto scaffold gantries with its small 1.35 x 0.95m platform and flat cable bin.

With two separate controls, this material hoist can be easily transformed into a transport platform, approved for carrying up to three passengers.

The 300Z/ZP is also available as a 240v single-phase version.

- 3 phase 415v or single phase 240v power supply.
- lifting speed 12 m/min (415v) 9 m/min (240v).
- Load capacity 300kg (240v) or 500kg (415v).
- Compact and quick to install especially through a narrow gate of 0.85m.
- Height Range to 50m.
- Trailer delivery.



Can be pulled through a small opening

Loading the hoist at the base position

Hoist at landing position



Power requirements

Dedicated 240v 32a Commando Socket.

Dedicated 415v 32a 5 Pin Commando Socket.

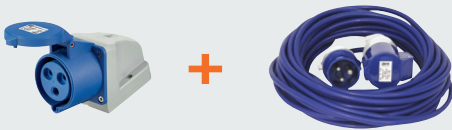

OR ...



32a Single Phase C Type MCB /
32a Three Phase C Type MCB.

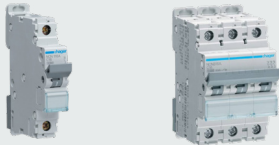

Can be paired with a 22kva Generator



	Geda 300zzp 240v Single Phase	Geda 300zzp 415v Three Phase
Maximum Height	50m	50m
Lifting Capacity - Goods Mode	300kg	500kg
Lifting Capacity - Personnel Mode	3 persons	3 persons
Lifting Speed - Goods Mode	12 m/min	12 m/min
Lifting Speed - Personnel Mode	9 m/min	12 m/min
Power Source	240v Electric	415v Electric
Breaker Rating	32a Single Phase C Type MCB	32a Three Phase C Type MCB
Power Requirements (Within 2m of the hoist base)	Dedicated 240v 32a Commando Socket	Dedicated 415v 32a 5 Pin Commando Socket
Start up Current (Max)	31a	23a
Running Current (Max)	11a	4.6a
Cage Dimensions (Internal)	W 950mm - L 1350mm	W 950mm - L 1350mm
Approx. Ground Space Required	2700mm x 2700mm	2700mm x 2700mm
Approx. Minimum Access Required	W 850mm - L 1510mm - H 2300mm	
Approx. Gate Opening Dimentions	2000mm +	2000mm +

Technical information

Standard configuration.

Platform size.

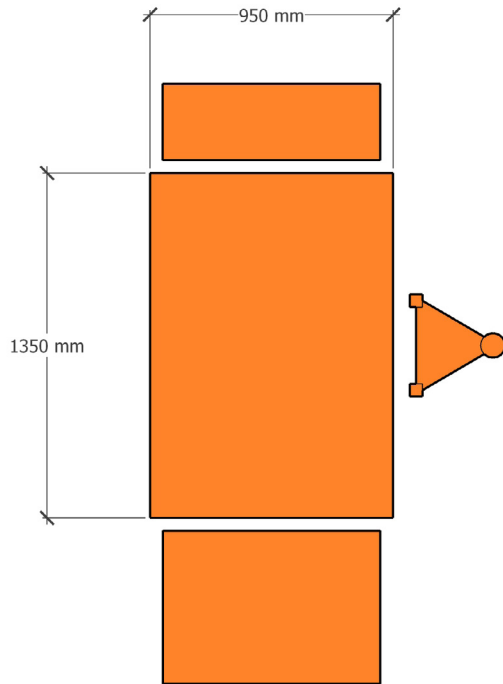

Reversed configuration.

Platform size.

